

# Innovative two-pipe system for simultaneous heating and cooling of office buildings

Alessandro Maccarini

Alireza Afshari

Niels Christian Bergsøe

# Table of contents

Background .....	3
Active beams .....	3
Concept .....	4
Objective .....	6
Articles .....	6
Methods.....	7
Modelica .....	7
Development of an active beam model in Modelica .....	8
Two-pipe system in a two-room model.....	10
Development of an advanced controller for the supply water temperature ...	12
Detailed modeling of the two-pipe system in an office building.....	15
Results and discussion.....	18
Ideal configuration – Energy savings due to heat transfer between zones ...	18
Ideal configuration with dry cooler – Energy savings due to free cooling .....	19
Real configuration – Energy savings due to higher COP of the heat pump ..	20
Real configuration – Total energy savings .....	20
Conclusions.....	23

This report was specifically written for ELFORSK/PSO. The contents of this report should not be shared or published since they are the fundamentals of a PhD thesis.

# Background

Energy consumption in buildings is a large share of the world's total end-use of energy. In member states of the European Union, residential and commercial buildings require approximately 40% of the end-use of energy. Thus, the potential savings of energy efficiency in the building sector would greatly contribute to a society-wide reduction of energy consumption. The implications of such potential reduction should not be underestimated, as the scale of low-energy buildings is large enough to influence security policy, climate preservation and public health on a national and global scale.

Heating, ventilation and air-conditioning (HVAC) systems represent the largest energy end-use both in residential and commercial buildings, accounting for almost half the energy consumed in buildings. Most of this energy is used for maintaining a room temperature of about 20 °C, which is close to ambient conditions and therefore requires a low content of exergy. However, in most cases HVAC systems supply energy to buildings by high quality energy sources (high exergy systems), such as fossil fuels. Extensive usage of fossil fuels causes several environmental and energy issues, such as global warming, pollution and depletion of fossil natural resources.

Recent researches showed that energy demands of buildings can be supplied by using innovative heating and cooling systems (low exergy systems) with very small temperature differences between heat carrier medium and the room. Low exergy systems are defined as heating and cooling systems that allow the use of low valued energy, which can be delivered by sustainable energy sources (e.g. heat pumps, solar collectors, waste heat, energy storage). Therefore, the use of low-exergy systems can reduce the environmental impact of buildings, and play a crucial role towards the European requirements of nearly zero-energy buildings by 2018. In the context of low-exergy systems, active beams represent a valuable alternative to traditional HVAC systems.

## Active beams

Active chilled beams (ACBs) have been used for more than 20 years in Europe, mainly for cooling purpose, and increasing interests in these systems have been found in North America and Asia during the last decade. Nowadays, ACBs systems can be used for both cooling and heating of buildings and they can be simply called "active beams".

When comparing ACBs with traditional all-air variable air volumes systems (VAV), energy use can be reduced in various ways. First of all ACBs decouple ventilation load from space sensible load, handling space cooling and outside air requirements without increasing airflow rate. Secondly, the employment of higher chilled water temperature (13°C to 17°C) than conventional HVAC systems (4°C to 7°C) lead to higher efficiency of the cooling machine. Comparison reports of the energy performance of ACBs with conventional HVAC systems

show that the impact varies appreciably depending on the specific project and the climate location, but energy savings of 8-20% can be achieved. Recently, in order to fully understand the benefits of ACBs, several research studies have been conducted. At Statens Byggeforskningsinstitut (SBI), Aalborg University (AAU), research was done on an innovative two-pipe active beam system for simultaneous heating and cooling of office buildings.

## Concept

Simultaneous heating and cooling demand occurs frequently in office buildings. A four-pipe system is the traditional approach to deal with this situation as it has the ability to provide heating to one zone and cooling to another zone at the same time by operating with two separated hydronic circuits (Fig.1).

The characteristic of the innovative two-pipe system is its ability to provide simultaneous heating and cooling by transferring energy between zones with one hydronic circuit, operating with a water temperature between 20°C and 23°C (Fig.2).

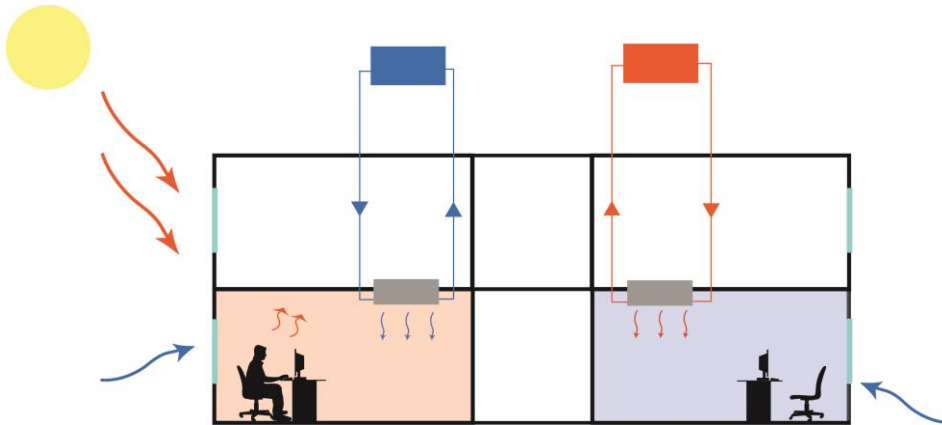

Figure 1. A conventional four-pipe system dealing with simultaneous heating (right room) and cooling (left room)

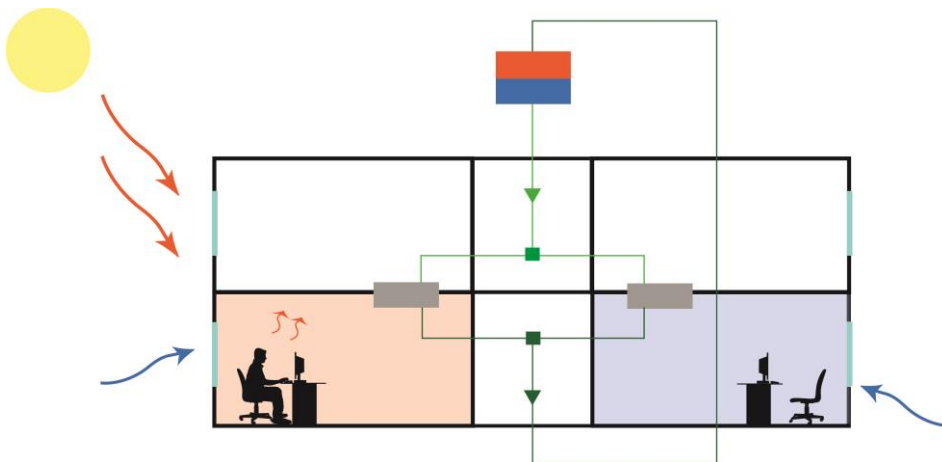

Figure 2. The innovative two-pipe system dealing with simultaneous heating (right room) and cooling (left room)

Running high-temperature cooling and low-temperature heating in the same circuit actually means that both heating and cooling have the same inlet water temperature. Output hot and cold water is mixed together and as a result the system only needs to cool or heat the water to reach the inlet temperature once again. By only having to cool or heat the water, no energy is wasted as this is done at the same time.

To analyze the energy performance of the innovative two-pipe and predict potential energy savings, a simulation-based research has been developed.

# Objective

The main objective of this project is to evaluate the energy performance of the previously described two-pipe system through a detailed modeling and simulation approach. Potential energy savings are calculated in comparison with a conventional four-pipe system.

## Articles

The present report is based on the following scientific articles (I to IV), which are prepared in connection with the completion of a PhD project at the Danish Building Research Institute at Aalborg University, Copenhagen. Additional results and scientific articles will be presented in the PhD thesis.

- I. Maccarini, Alessandro, Alireza Afshari, Niels Christian Bergsøe, Göran Hultmark, Magnus Jacobsson, and Anders Vorre. n.d. "Innovative Two-Pipe Active Chilled Beam System for Simultaneous Heating and Cooling of Office Buildings." In *Proceedings 13th International Conference on Indoor Air Quality and Climate*, 7–12 July, 2014, Hong Kong.
- II. Maccarini, Alessandro, Alireza Afshari, Göran Hultmark, Niels C Bergsøe, and Anders Vorre. n.d. "Modeling of a Novel Low-Exergy System for Office Buildings with Modelica." In *Proceedings 12th REHVA World Congress*, 23–26 May, 2016, Aalborg, Denmark.
- III. Maccarini, Alessandro, Göran Hultmark, Anders Vorre, Alireza Afshari, and Niels C. Bergsøe. 2015. "Modeling of Active Beam Units with Modelica." *Building Simulation* 8 (5): 543–50. doi:10.1007/s12273-015-0236-5.
- IV. Maccarini, Alessandro, Michael Wetter Alireza Afshari, Göran Hultmark, Niels C. Bergsøe and Anders Vorre. (2017). "Energy saving potential of a two-pipe system for simultaneous heating and cooling of office buildings." *Energy and Buildings*, 134, 234-247

# Methods

Computer modeling and simulation is a powerful technology for calculating energy performance in buildings. For the past 50 years, a variety of Building Performance Simulation tools (BPS) have been developed and used by the building energy research community and by building designers. These tools perform simulations and calculate the energy performance of a building by solving a system of equations that describes the thermal behavior of the envelope and the HVAC system. Climate, schedules of operation and internal loads are the boundary conditions of simulations.

Previous preliminary studies were carried at SBi in order to analyze the energy performance of the two-pipe system. Energy simulations were performed by using common BPS tools. However, the use of common BPS tools presented three main limitations:

- 1) No active beam models were available for both heating and cooling
- 2) Heating and cooling were treated as two separate processes
- 3) No possibilities for customized control strategies

It became clear that a more flexible modeling tool was necessary for a comprehensive investigation of the two-pipe system. Therefore, Dymola, a commercial simulation environment for Modelica models, was chosen for this study.

## Modelica

Modelica, developed by the Modelica Association, is a freely available, object-oriented equation-based language for modeling large, complex, and heterogeneous physical systems. It has been used for almost two decades, especially in the design of multi-domain engineering systems such as mechatronic, automotive and aerospace applications involving mechanical, electrical, hydraulic and control subsystems. The use of Modelica has only recently extended to the building energy research community, because of the upcoming need for more complex and efficient energy systems and the availability of open-source libraries for building HVAC applications.

Currently, several Modelica libraries exist for building components and HVAC systems, and these are continuously being upgraded. Moreover, the International Energy Agency (IEA) has undertaken a large-scale international project (IEA ECB Annex 60, <http://iea-annex60.org/>) with the aim to develop a new generation of computational tools for building energy systems based on Modelica. Models from the *Buildings* library v2.1.0 were used in this work

## Development of an active beam model in Modelica

Currently, no active beam model has been included in any of the available Modelica libraries. However, one of the main features of Modelica is the possibility to develop new models and connect them to existing libraries. Therefore, the development of a new Modelica model able to simulate the physical behavior of active beams for both heating and cooling was the first step in order to build the whole two-pipe system.

Schematic diagram of a general active beam unit is given in Fig. 3. It consists of a primary air plenum, a mixing chamber, a heat exchanger and several nozzles. The heat exchanger is served by a water circuit. The primary air is discharged to the mixing chamber through the nozzles. This generates a low-pressure region which induced air from the room up through the coil. The conditioned induced air is then mixed with primary air, and the mixture descent back to the space.

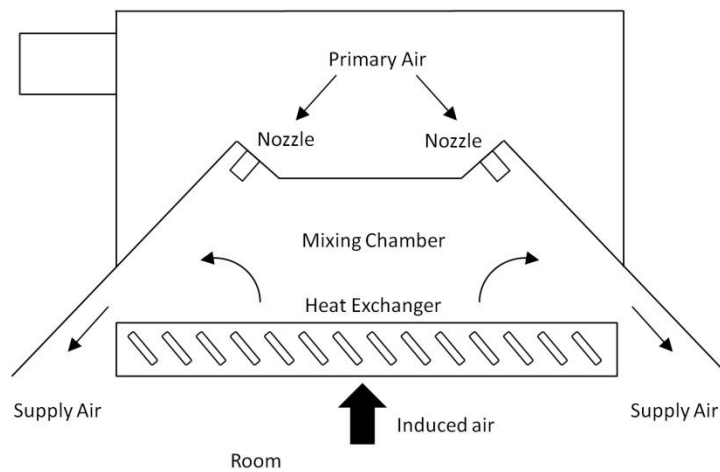

Figure 3. Diagram of an active beam unit

A system of equations describing the heat transfer behavior of active beams is given hereinafter. The total capacity of an active beam unit is the sum of capacities provided by the primary air and the water.

$$P = P_a + P_w \quad (1)$$

The following equation calculates the capacity provided by the primary air

$$P_a = \dot{m}_{ap} c_{p,a} (T_r - T_a) \quad (2)$$

Heat transfer through the coil is described by the following system of equation under steady-state conditions and assuming no condensation on the coil surface.



$$P_w = \dot{m}_w c_{p,w} (T_{w,out} - T_{w,in}) \quad (3)$$

$$P_w = kA(T_r - T_{w,avg}) \quad (4)$$

$$P_w = \dot{m}_{ai} c_{p,a} (T_{a,in} - T_{a,out}) \quad (5)$$

The values of  $k$  and  $\dot{m}_{ai}$  were determined by using empirical equations derived from manufacturers. Fig. 4 shows the active beam model developed in Modelica.

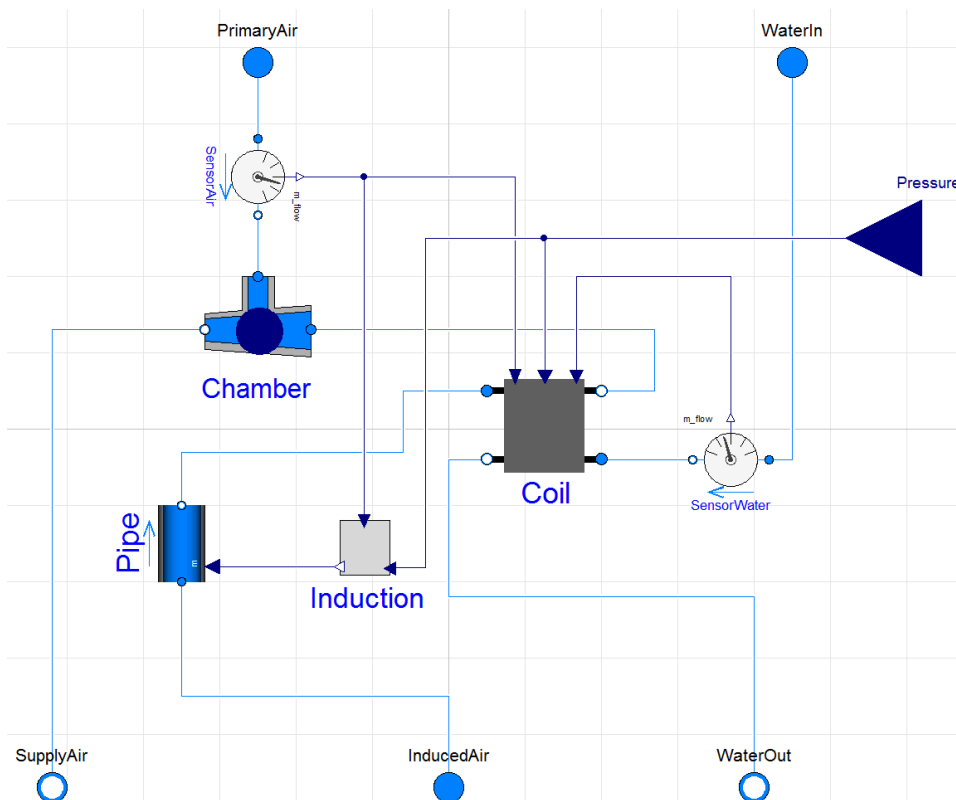

Figure 4. Graphic layout of the active beam model developed with Dymola

In order to validate the model, experimental analyses were performed. The experimental data collection was conducted at Lindab A/S laboratories in Farum, Denmark. A Solus active beam unit (manufactured by Lindab A/S) was mounted on a test room 3 m length, 4 m width and 2.6 m height.

To validate the model, four case studies were performed. Heating and cooling loads were delivered to the test room in order to vary room air temperature and mimic situations of cooling and heating demand. Room temperature was measured with a sensor placed at 1.7 m height in the center of the room.

The model accuracy was evaluated by comparing predicted and experimental outlet water temperature.

In the Fig. 5, water outlet temperature is compared by depicting simulated and measured data vs. time for a representative case study. Estimated results match well with monitoring data and a similar qualitatively behavior is observed.

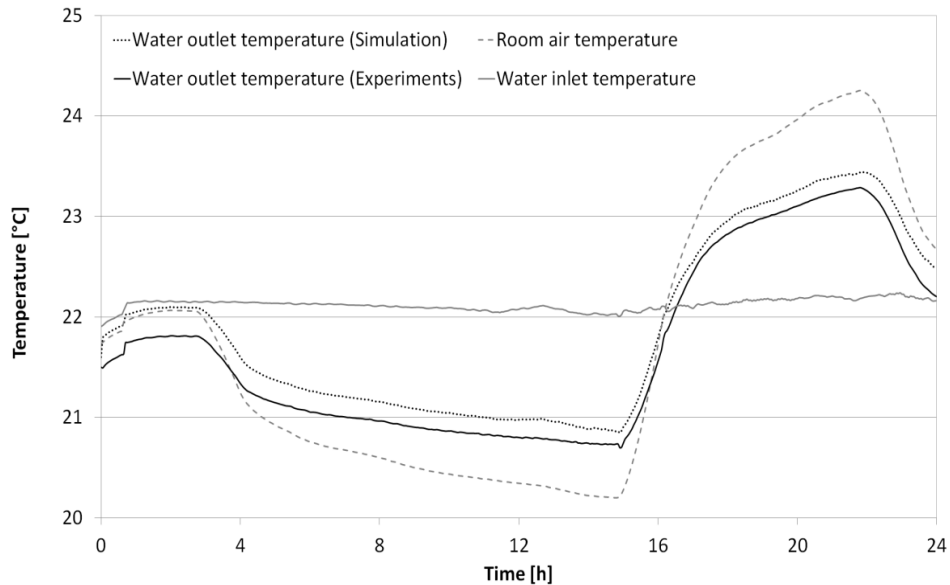

Figure 5. Experimental vs. simulated data

## Two-pipe system in a two-room model

The model of the active beam previously developed was necessary in order to build a detailed model of the two-pipe system.

A simulation study was performed in order to demonstrate the modeling approach of the two-pipe system with Modelica. This case study involved the analysis of the two-pipe system connected to two office rooms for three typical weeks: winter, spring and summer.

The system was modeled by using basic components of the Modelica *Buildings* library, a free open-source library with dynamic simulation models for building energy and control systems. Figure 6 shows the model of the novel system developed with Dymola

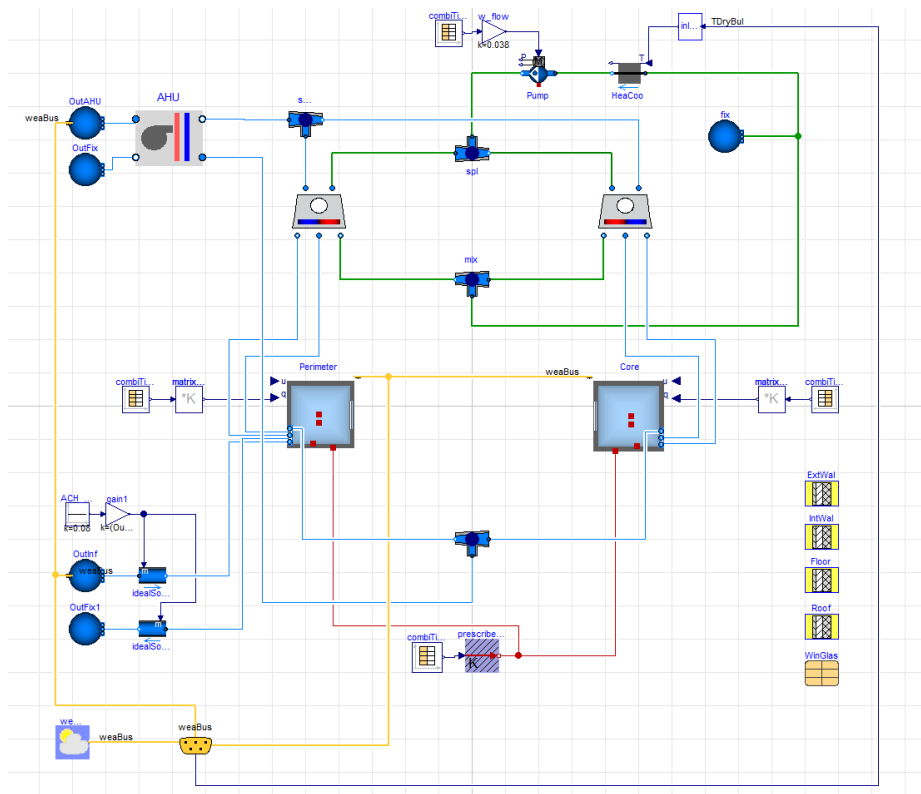

Figure 6. Modelica model of the two-pipe system connected to two rooms

A perimeter and a core office room were chosen for the simulation case study. Both rooms had the following dimensions: 4 m length, 4 m width and 3 m height. The perimeter zone was assumed to have an external wall (north orientation), a floor and a roof. A double pane window of 3.6 m<sup>2</sup> was placed on the external wall. The core zone was assumed to have a floor and a roof. Internal walls were considered adiabatic. Table 1 shows the thermal properties of the constructions elements.

Tab. 1 Thermal properties of construction elements

Construction element	U-value (W/m <sup>2</sup> K)
External Wall	0.31
Roof	0.18
Floor	1.83
Double-pane window (SHGC=0.4)	2.37

Infiltration rate was set equal to 0.08 air change hour for the perimeter zone. Internal heat gains were selected to be equal to 8.83 W/m<sup>2</sup> for lighting, 8 W/m<sup>2</sup> for equipment and 6.46 W/m<sup>2</sup> for occupants during working hours (7 am-6 pm). The climatic boundary conditions of Copenhagen (Denmark) were chosen for simulations.

As previously mentioned, the two-pipe system integrated only one water circuit for both heating and cooling. Therefore, the supply water should have temperature levels similar to indoor thermal comfort conditions. A controller regulated the supply water temperature between 23 °C and 20 °C based on outdoor air temperature. Fig. 7 shows the relationship between water and outdoor air temperature.

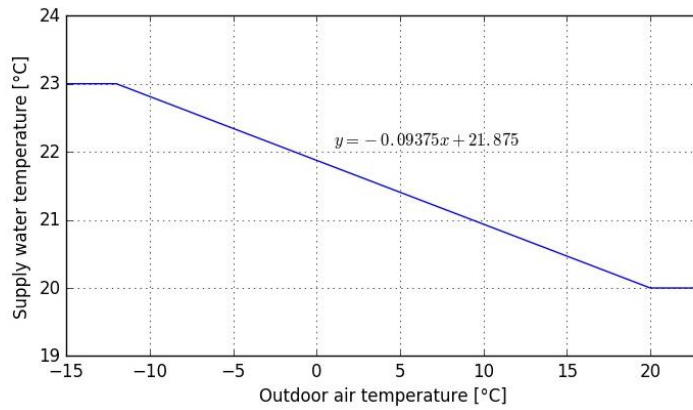

Figure 7. Correlation between supply water temperature and outdoor air temperature

Fig. 8-10 show the air temperature profiles of the two office rooms and the supply water temperature during the three typical weeks. Comfortable levels of indoor air temperature were provided by the two-pipe system during all the three periods. It can be noticed that, during the winter week, the supply water temperature lies between the perimeter and core air temperature for almost all the working hours. As described in the “Results and discussion” section, this behavior lead to heat transfer between zones, and as consequence, energy savings. The figures also show that the air temperature profiles do not follow any set-point. This means that the actual air temperatures depend only on the supply water temperature, which depends on the outdoor air temperature (see fig. 7). This control strategy has the advantage of being very simple, since it does not require any thermostat in the single rooms. However, a more sophisticated controller would lead to higher energy performance of the system.

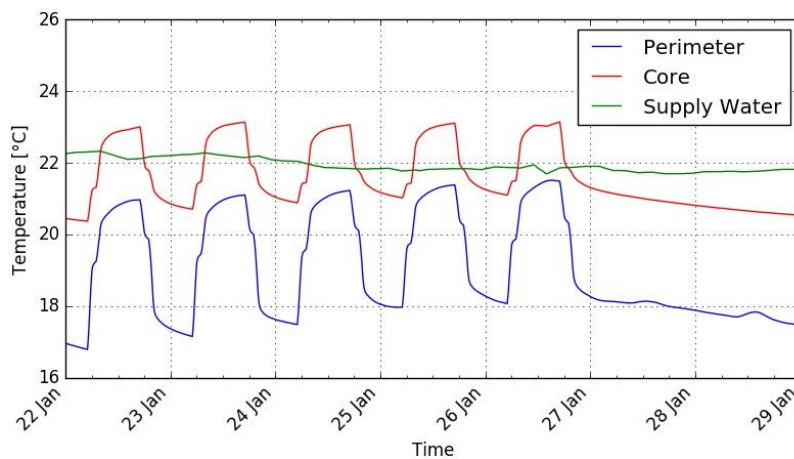

Figure 8. Winter week. Air and supply water temperature

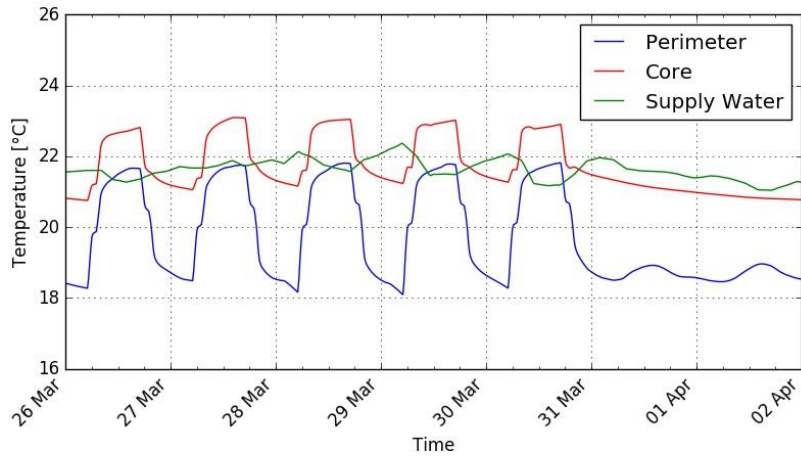

Figure 9. Spring week. Air and supply water temperature

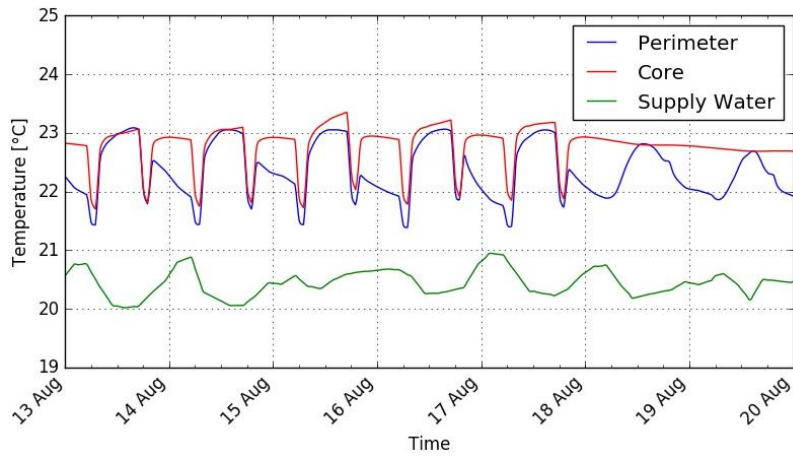

Figure 10. Summer week. Air and supply water temperature

## Development of an advanced controller for the supply water temperature

In the previous section, the modeling approach of the two-pipe system was described when connected to two office rooms. As mentioned, the supply water temperature represents a crucial parameter to be controlled.

In order to develop a more efficient way to regulate the system, an advanced controller was modelled in Modelica.

The controller was developed by using basic components of the Modelica Standard Library (MSL). The controller was designed to track indoor air temperatures in the rooms and set a proper supply water temperature. Fig. 11 shows a diagram of the controller developed in Dymola.

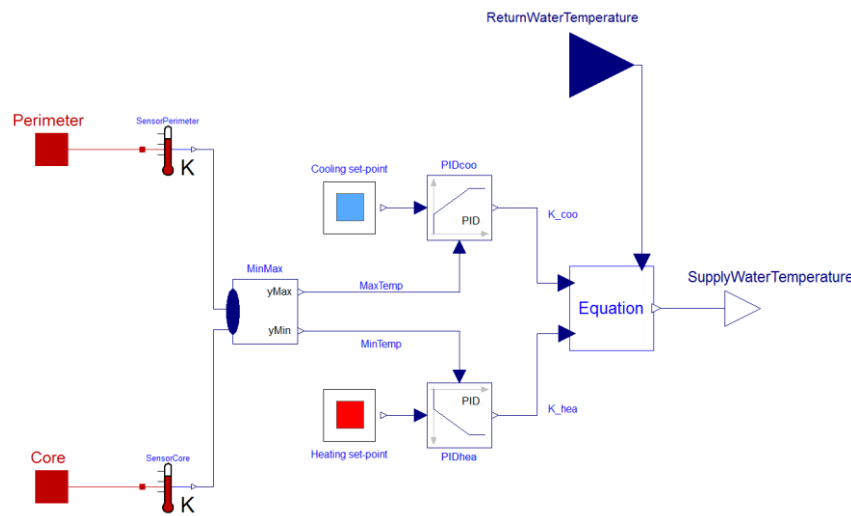

Figure 11. Modelica model of the controller for the supply water temperature

The supply water temperature can be expressed by the following equation:

$$T_{sup} = T_{ret} + k_{hea} - k_{coo} \quad (6)$$

Where  $T_{ret}$  is the return water temperature and  $k_{hea}$  and  $k_{coo}$  are offsets able to adjust the return water temperature based on current air temperatures in the rooms and set-point temperatures.

The controller is fed by the signals of actual air temperatures in the rooms and return water temperature. The block *MinMax* evaluates the minimum and maximum air temperature among the two rooms. The minimum temperature is an input for the block *PIDhea*, where it is compared with the heating temperature set-point. If the minimum air temperature is above the set-point,  $k_{hea}$  is equal to 0. Otherwise, the PID controller evaluates the value of  $k_{hea}$  to be added to  $T_{ret}$  to meet the heating set-point.

The maximum temperature is an input for the block *PIDcoo*, where it is compared with the cooling temperature set-point. If the maximum air temperature is below the set-point,  $k_{coo}$  is equal to 0. Otherwise, the PID controller evaluates

the value of  $k_{\text{cool}}$  to be deducted from  $T_{\text{ret}}$  to meet the cooling set-point. As a consequence, whenever both room air temperatures are within the heating and cooling set-point range,  $k_{\text{heat}}$  and  $k_{\text{cool}}$  are equal to 0 and, therefore, the supply water temperature is set equal to the return water temperature, requiring for no energy in the plant.

## Detailed modeling of the two-pipe system in an office building

In the previous sections, the necessary components and strategies for a detailed modeling of the two-pipe system were introduced. Therefore, now it is possible to develop a comprehensive model of the two-pipe system and connect it to an office building model. The geometry of the building model is illustrated in Fig. 12.

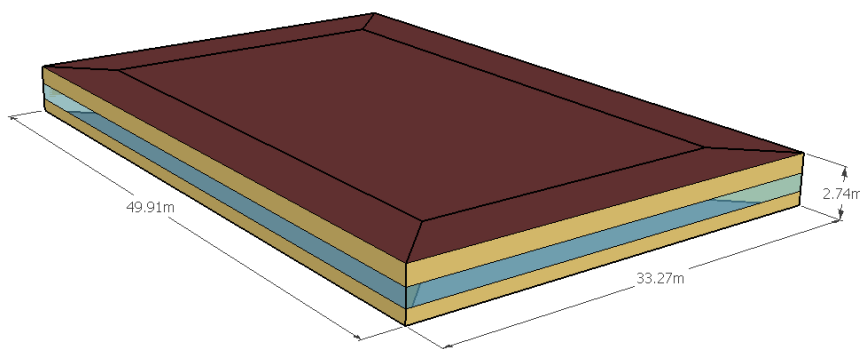

Figure 12. Geometry of the office building

It consists of four perimeter thermal zones and one core thermal zone. The total floor area is  $1660 \text{ m}^2$  with an aspect ratio of 1.5. This five-zone model is representative of one floor of the medium office building prototype, as described in the report, U.S. Department of Energy Commercial Reference Building Models of the National Building Stock. The report characterizes 16 prototype buildings for 16 climate zones covering the majority of the US commercial building stock. These building models have been developed to serve as a starting point for energy efficiency research, as they represent fairly realistic buildings and typical construction practices.

The thermal properties of the building elements are the same as shown in Tab. 1. The windows were evenly distributed along all facades, with a window-to-wall ratio of 0.33. In accordance with the prototype office building models, no shading devices were applied to the windows. The weather conditions of Copenhagen (Denmark) were used.

The graphic layout of the system modelled in Dymola is shown in Fig. 13. It consists of a room-temperature water loop for space heating and cooling and an air loop for ventilation. The pump circulates a constant water mass flow rate in the room-temperature loop. Heating and cooling loads are met by adjusting the supply water temperature through the controller previously described. Heating and cooling set-points are respectively  $21 \text{ }^\circ\text{C}$  and  $24 \text{ }^\circ\text{C}$ . The plant provides energy to the return water flow to track the supply temperature set-point. Water enters the active beam terminal units in which, together with the primary air delivered by the air handling unit (AHU), it exchanges heat with the rooms.

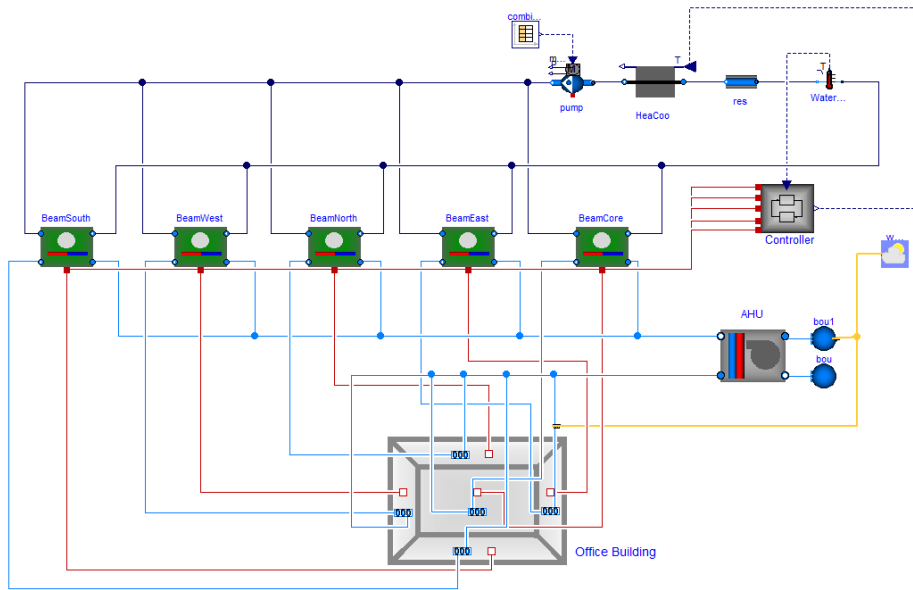

Figure 13. Modelica model of the two-pipe system connected to a five-zones building model

Exhaust air from the rooms is distributed to a heat recovery device in the AHU. The AHU also consists of heating and cooling coils that control the primary air temperature. A fan supplies a constant air mass flow rate to the building.

The two-pipe system was modelled for three different configurations. Each configuration aimed to highlight a different aspect of the energy savings of the two-pipe system. The three configurations were defined as:

- 1) Ideal configuration
- 2) Ideal configuration with dry cooler
- 3) Real configuration

The ideal configuration included Modelica models of ideal plants for both the water and air loops. This means that the energy use has to be considered as useful energy use, which can be defined as the energy required once all the losses have been deducted from the delivered amount of energy. These ideal plants calculated the thermal power delivered to the water stream as

$$\dot{Q} = \dot{m}_w c_{p_w} \Delta T_w, \quad (7)$$

where  $\dot{m}_w$  is the water mass flow rate,  $c_{p_w}$  is water specific heat capacity and  $\Delta T_w$  is the water temperature difference between supply and return. This ideal configuration allowed prediction of the actual energy savings related to the useful heat transferred from warm to cold rooms by the room-temperature loop when simultaneous heating and cooling occurred.

In the second system configuration, a dry cooler was added to take advantage of free cooling. The dry cooler was dimensioned to be able to cool the return



water to the design temperature condition of 20°C with a temperature difference of 6 K between water and outside air. Therefore, whenever the outside air temperature was below 14°C, no cooling energy was required by the water plant in the room-temperature loop.

In the third system configuration, the ideal models were replaced by more realistic components. In particular, a reversible air-to-water heat pump model was integrated into the room-temperature loop. Furthermore, the AHU heating coil was supplied by a heat pump with a supply water temperature of 45°C, while the cooling coil was connected to a chiller with a supply water temperature of 7°C. Average efficiencies for pumps and fans were set to 0.8.

At the full flow rate, the total pressure drop in the water loop was assumed to be 35 kPa, and the total pressure drop in the ventilation loop was assumed to be 500 Pa.

## Results and discussion

In order to compare the energy savings of the two-pipe system (2PS), a comparative study was conducted in respect to a conventional four-pipe system (4PS). Yearly dynamic simulations were run in Dymola version 2016 on a Windows machine. The annual energy use was calculated for both the 2PS and the 4PS. These simulations were done three times, one for each configuration of the system.

### Ideal configuration – Energy savings due to heat transfer between zones

Fig. 14 shows the comparison of the annual heating and cooling useful energy use for the first system configuration. As illustrated, the 2PS required less useful heating and cooling energy than the 4PS. In particular, the 2PS used 23.3 kWh/m<sup>2</sup> per year while the 4PS used 28 kWh/m<sup>2</sup> per year.

The energy savings due to heat transfer between rooms can be illustrated by comparing the total heating and cooling thermal power provided by the central plant for a typical winter day, as shown in Fig. 15. At the beginning and at the end of the day, due to the absence of internal heat gains, the building only needs heating. Therefore, both systems present the same profile. In the middle of the day, while the 4PS has to provide separate heating to perimeter zones and cooling to the core zone, the 2PS is able to provide heating and cooling simultaneously. As a consequence, almost no energy is required.

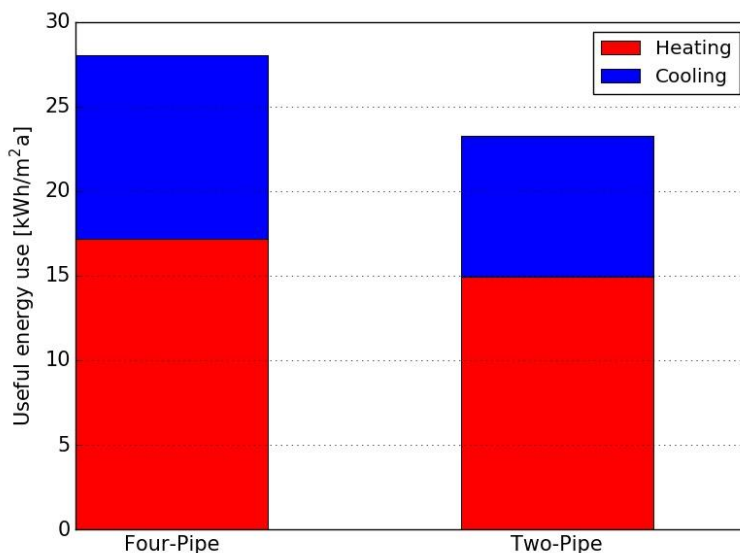

Figure 14. Useful energy use – Ideal configuration

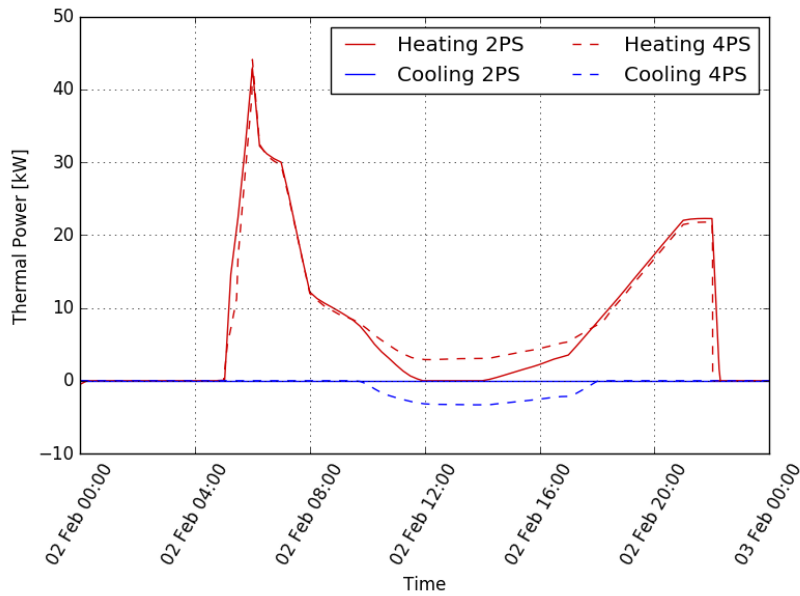

Figure 15. Thermal power during a typical winter day

### Ideal configuration with dry cooler – Energy savings due to free cooling

Fig. 16 illustrates the annual useful cooling energy use for the second system configuration. In this configuration, a dry cooler was added to both the two-pipe and four-pipe system. Due to a higher supply water temperature than the 4PS, the 2PS was able to take better advantage of free cooling conditions. The 2PS presents a significantly higher value of heat removed. In particular, the dry cooler in the 2PS removed approximately 70% of cooling demand versus 33% in the 4PS, respectively.

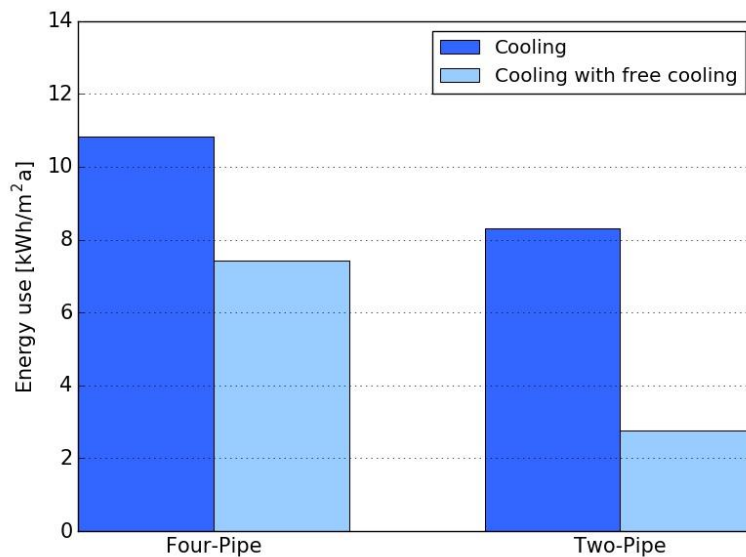

Figure 16. Useful energy use for cooling– Ideal configuration with dry cooler

## Real configuration – Energy savings due to higher COP of the heat pump

Fig. 17 shows the annual thermal and electric energy use for the third system configuration in heating mode. Here, the ideal plant was replaced by a heat pump.

Additional energy savings were obtained thanks to the smaller temperature difference between evaporator and condenser in heating mode. The heat pump in the 2PS presented a Heating Seasonal Performance Factor (HSPF) 48% higher than the heat pump in the 4PS. The HSPF is defined as:

$$\text{HSPF} = \frac{Q_{\text{hea}}}{W_{\text{el,hea}}}, \quad (8)$$

where  $Q_{\text{hea}}$  is the annual heat delivered to the water flow by the heat pump and  $W_{\text{el,hea}}$  is the annual electricity used. In particular, a HSPF value of 3.16 and 4.69 was found, respectively, for the 4PS and 2PS.

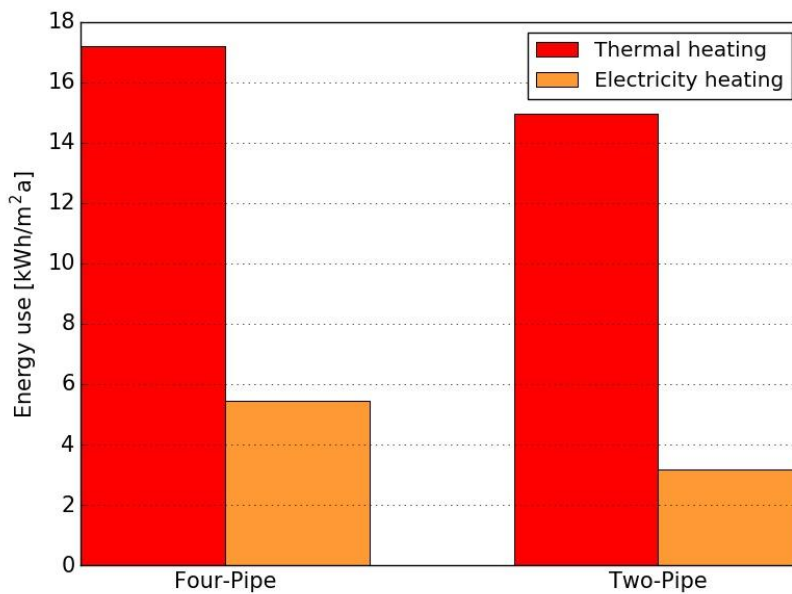

Figure 17. Energy use for heating – Real configuration

## Real configuration – Total energy savings

Fig. 18 shows the total annual primary energy use for the 2PS and 4PS. When comparing the total primary energy, the 2PS used approximately 18% less energy than the 4PS. As illustrated, fans account for a large share of the total energy, reducing the relative energy savings achieved due to the room-temperature loop. Since the 2PS circulated water continuously, pumps have higher energy use than the 4PS. It is worth mentioning that due to lower temperature differences between room air and water in the active beam, the 2PS requires approximately 4-times more heat transfer area than the 4PS. On the

other hand, the 2PS needs only one heat pump, fewer pipes and no control valves.

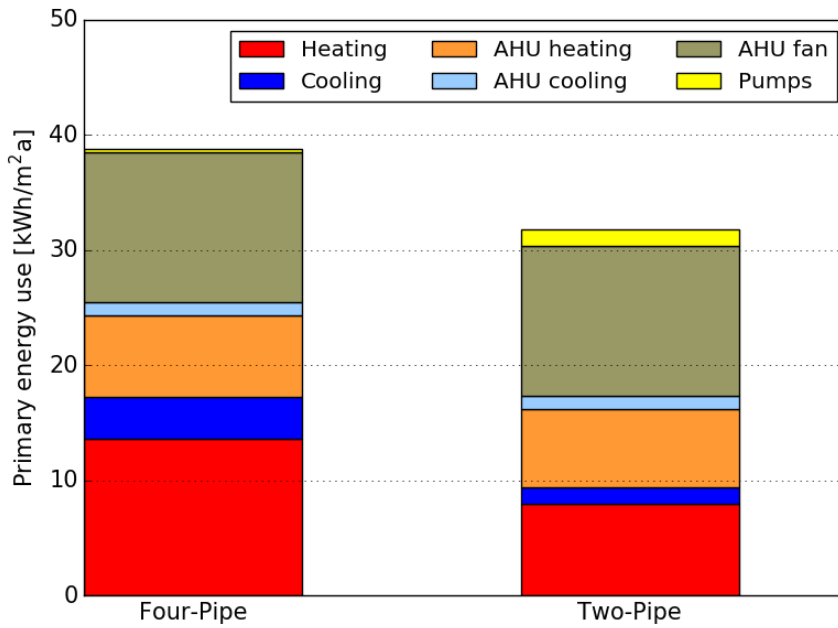

Figure 18. Total energy use – Real configuration

Figs. 19 and 20 illustrate the indoor air temperatures of the five rooms for a typical winter and summer day.

Supply and return water temperatures are also depicted in the graphs. Note that the controller for the supply water temperature set-point was able to maintain the room temperatures within the room temperature set-points. For the winter day, supply and return water temperatures at the central plant, after the return water of the beams is mixed, overlap during almost all of the working hours, leading to very little energy use. Relative high supply water temperatures were needed in the early morning and evening in order to meet the set-points. This is due to the absence of internal heat gains at the beginning and at the end of the operating hours

For the summer day, the supply water temperature is almost always lower than the return water temperature. This means that no energy savings due to heat transfer among zones occurred in the summer.

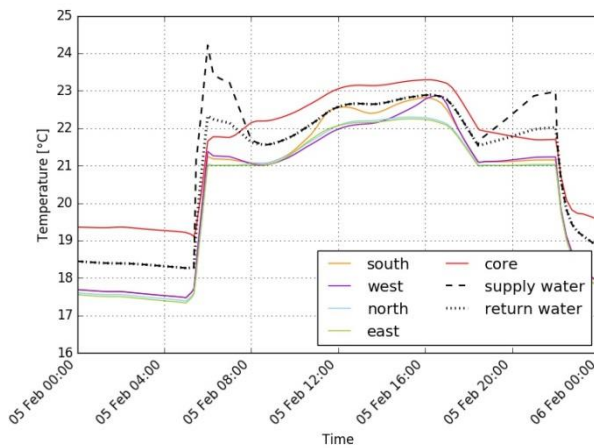

Figure 19. Indoor air temperatures and supply and return water temperatures for a typical winter day

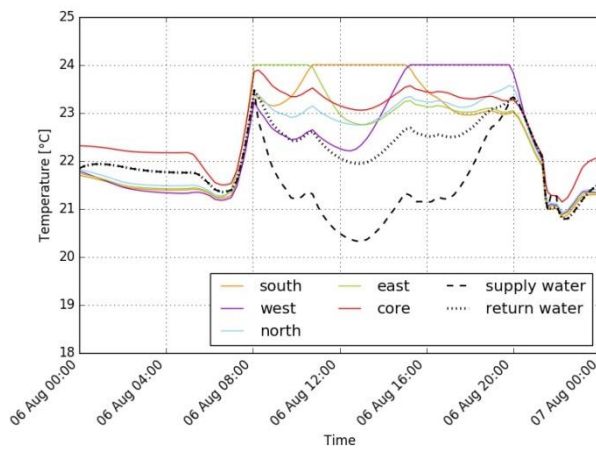

Figure 20. Indoor air temperatures and supply and return water temperatures for a typical summer day

It is worth mentioning that the design of the two-pipe system does not allow individual control of the air temperature in the thermal zones. The supply water temperature is adjusted by taking into account only the zone temperature corresponding to the maximum or minimum temperature among all the zones in the building at the current time. However, as shown in Figs. 19 and 20, proper dimensioning and control of the system ensures that air temperatures are always within the set-point values.

Real-life implementation of the two-pipe system is currently under development in an office building in Sweden. This will provide the possibilities for further investigations on energy performance, indoor thermal comfort and cost estimation.

# Conclusions

Using a room-temperature loop with supply water temperature of about 22°C, together with active beams, enabled the 2PS to meet room temperature set-points even though, simultaneously, some rooms required heating whereas others required cooling. The use of Modelica made it possible to develop a detailed and comprehensive energy and control model of the system. Simulation results showed that the two-pipe system was able to use less energy than the four-pipe system due to three effects: useful heat transfer from warm to cold zones, higher free cooling potential and higher efficiency of the heat pump. The following conclusions can be drawn:

- Due to the room-temperature loop layout, heat was transferred from the core zone to the perimeter zones. When considering only the energy use for space heating and cooling, savings between of approximately 21% occurred.
- Due to the higher supply water temperature in cooling mode, the dry cooler in the two-pipe system was able to remove more heat than the dry cooler in the four-pipe system. In particular, the dry cooler in the two-pipe system removed approximately 70% of cooling demand versus approximately 33% in the four-pipe system.
- Due to the lower supply water temperature in heating mode, the heat pump in the two-pipe system achieved a value of the HSPF 48% higher than the heat pump in the four-pipe system. This allowed for a significant reduction of primary energy use for space heating.
- When comparing the total annual primary energy use, the two-pipe system used approximately 18% less total primary energy (including ventilation) per year than the four-pipe system.
- The controller for the regulation of the supply water temperature was able to meet heating and cooling set-points in all the five rooms.